

Electric Hi Lo Screen lift 750 - Trolley Mount 8960

- Max Capacity 100kg - Min Capacity 5kg - Screens upto 86"

WARNING ! THIS IS NOT A TOY !

WARNING ! CHILDREN SHOULD NOT OPERATE LIFT OR HAVE ACCESS TO THE OPTIONAL REMOTE CONTROL !

WARNING ! THE LIFT MUST BE IN THE LOWEST POSITION WHEN MOVING IT AROUND!

Safety instructions

Use the following safety guidelines to help protect your lift from potential damage and to ensure your own personal safety.

- Read all the installation instructions before testing or installing your lift.
- Read and follow all safety instructions.
- Keep the optional remote control out of reach of children.
- To prevent bodily injury, keep hands and clothing away from the lift while the lift is in operation.
- Before installing the lift or working with its connections, unplug the lift from the mains power supply socket
- Do not place the lift in places subject to extreme temperatures for example near a radiator, or heating vent.
- The Electric lift must only be mounted in a dry area and it must be ensured before use that the lift is safe or protected from liquid contact or spillage.
- Unplug the lift IMMEDIATELY in the following conditions:
 - When the power cord or plug is damaged or frayed.
 - If liquid has spilled into the lift.
 - If the lift has been exposed to rain or water.
 - If the lift exhibits a distinct change in performance, indicating a need for servicing.
- MANUFACTURERS who build this Lift into other products or use it with other products, MUST make sure to prevent bodily injury. The MANUFACTURER is responsible to give the end user proper warnings and instructions for use.
- When adding a TV or any other equipment the party adding this TV or equipment is responsible for stability and security
- The lift should only be used on a flat floor area
- PAT Test Class 2 Equipment

Specifications and dimensions

Materials and weight:	Steel, black power coated- Weight 48kg (approx)
Min load:	5kg central loading
Max load:	100kg central loading
Operation:	Rocker switch or optional remote
Voltage consumption:	110-240VAC/ 50-60HZ 80 watt max (at 100kg) Standby <1 watt

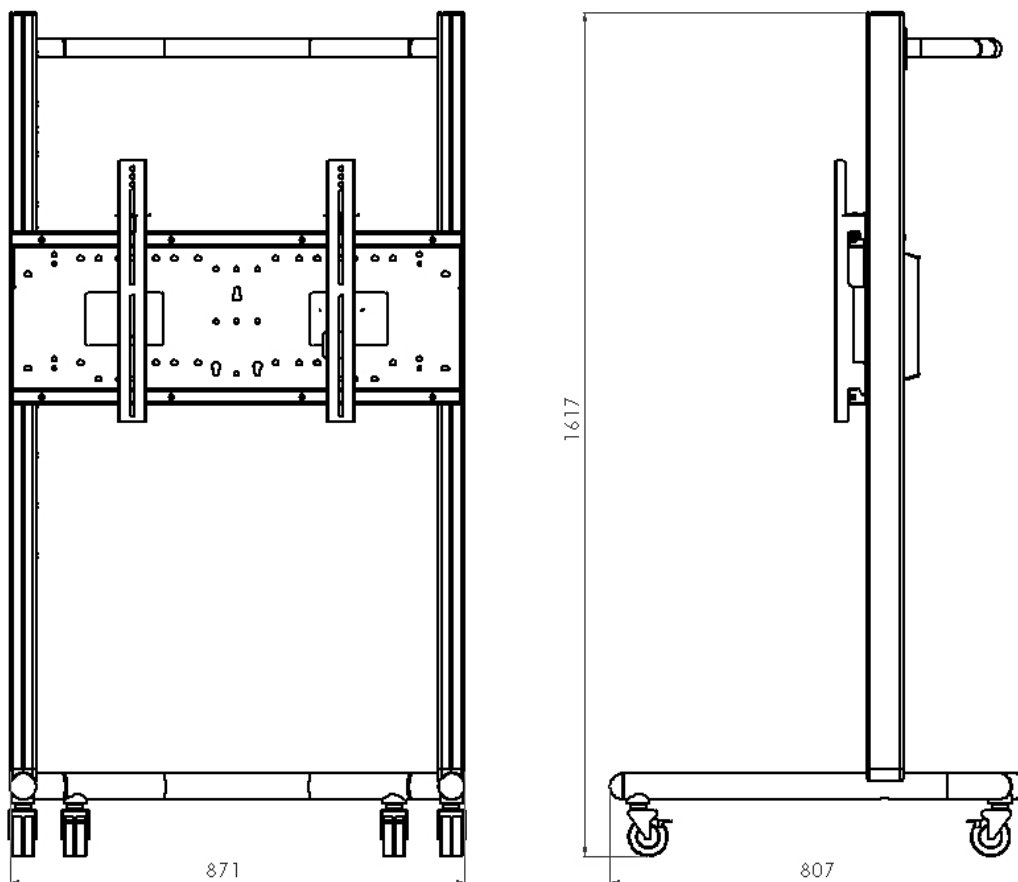

750mm Height adjustment.

PLEASE ENSURE THE SCREEN IS MOUNTED BEFORE ATTEMPTING TO OPERATE THE LIFT. IT IS DESIGNED TO BE OPERATED ONLY WITH WEIGHT ATTACHED .

1. Remove the back panel as shown.

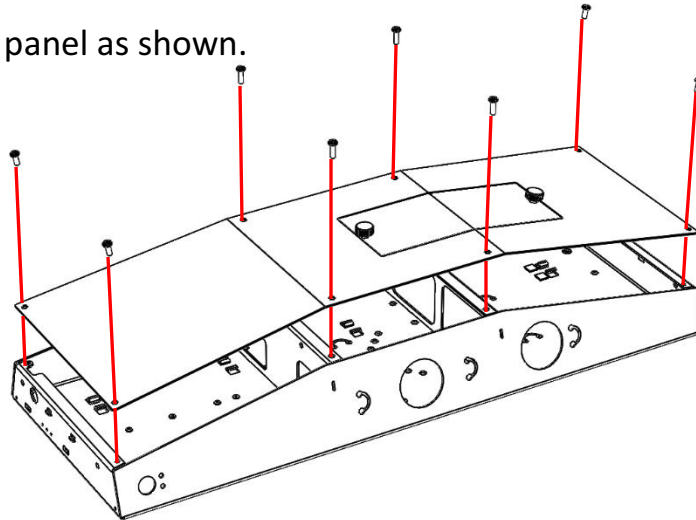

2. Remove protective tape from shafts and micro switches on the columns and motor box. Then slide the column shafts into the sockets in the motor box. Do this for both columns.

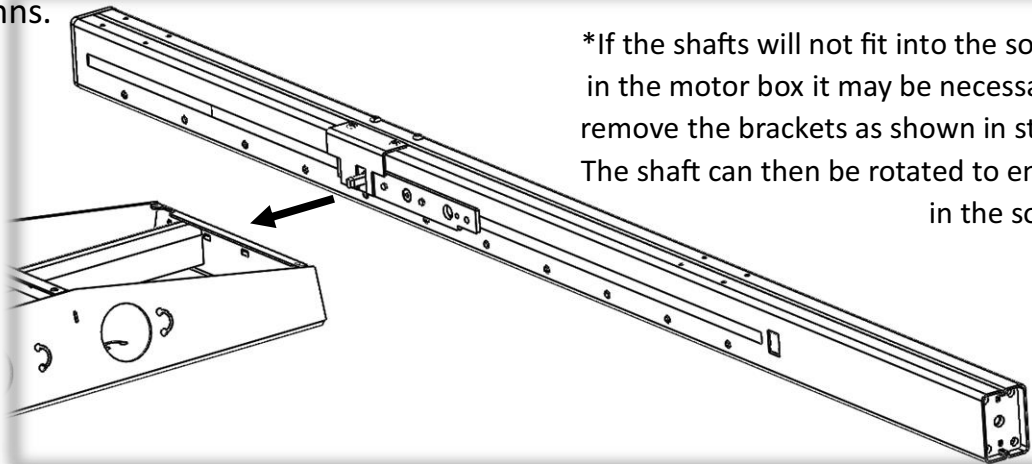

*If the shafts will not fit into the sockets in the motor box it may be necessary to remove the brackets as shown in step 3. The shaft can then be rotated to engage in the socket.

3. Gently remove the transportation brackets from columns as shown, put the bolts removed to aside for use later in the assembly process.

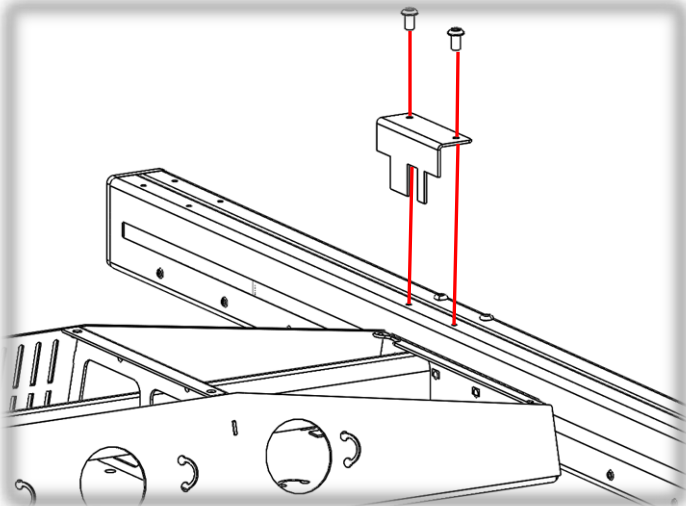

4. Using two M6 bolts to secure each column in place.

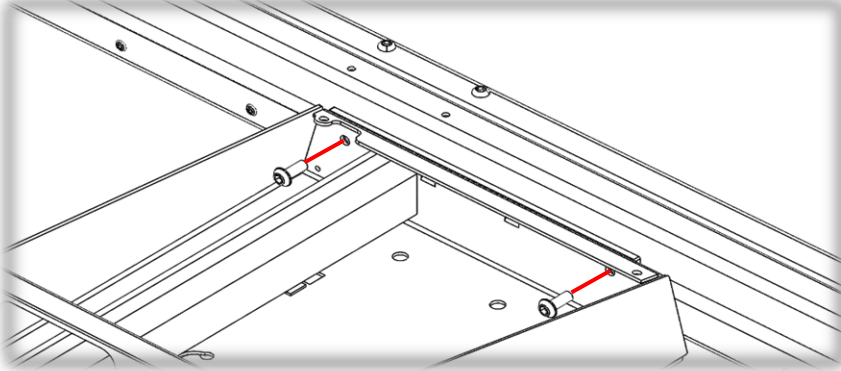

5. Plug the power cable into the transformer through the grommet indicated and bolt the rear panel in place.

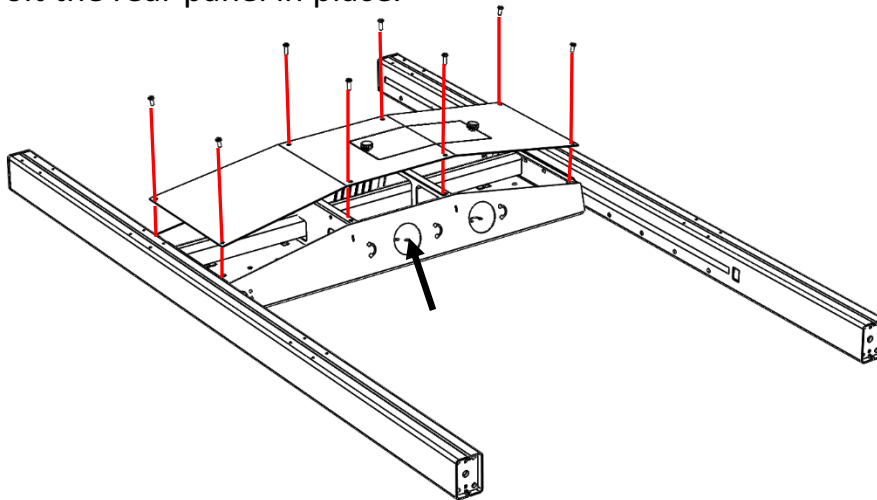

6. Attach the handle using the bolts you put aside in step 3 and the bolts already fitted in column. Use the top set of holes. Add the 16 caps into the holes indicated by the red arrows.

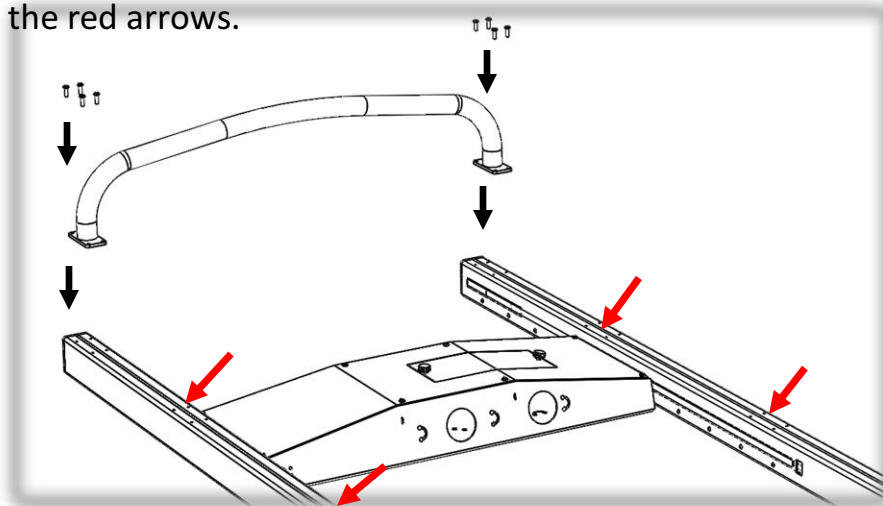

7. Bolt the base and casters in place using the M10 bolts and washers.

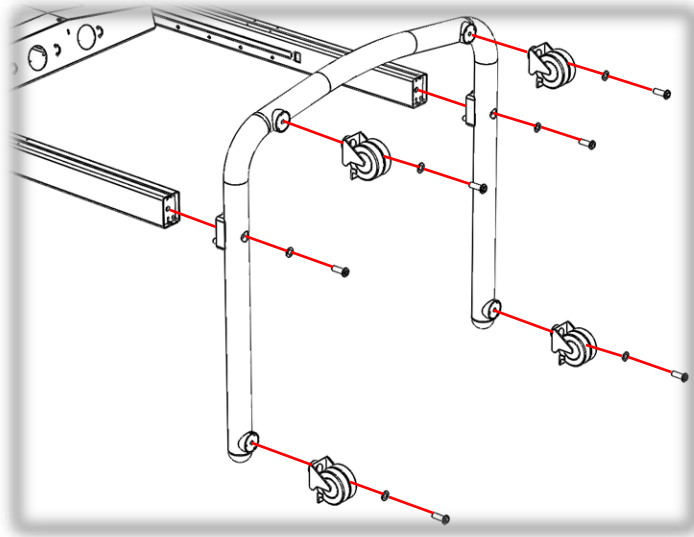

8. Use four M6 bolts to bolt the mount plate to the trolley.

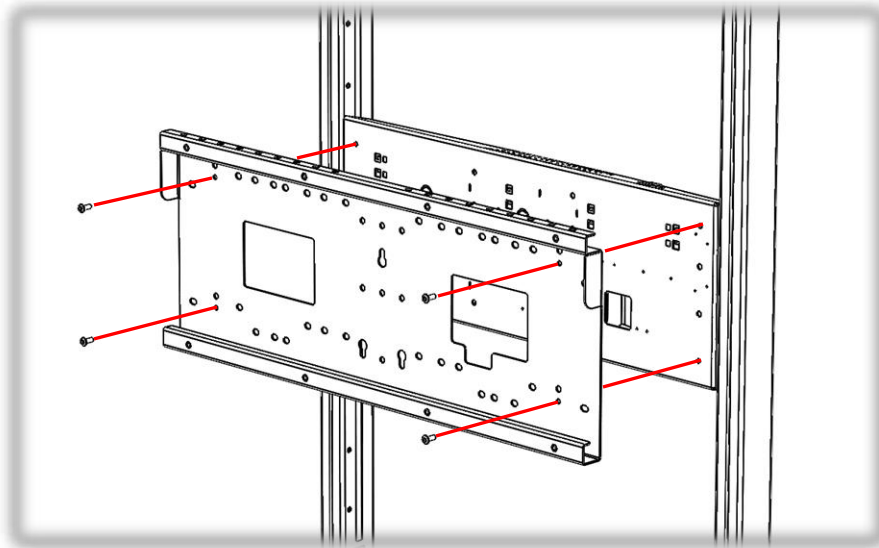

9. Attach the hangers to the back of the screen, make sure the hangers are as central as possible.

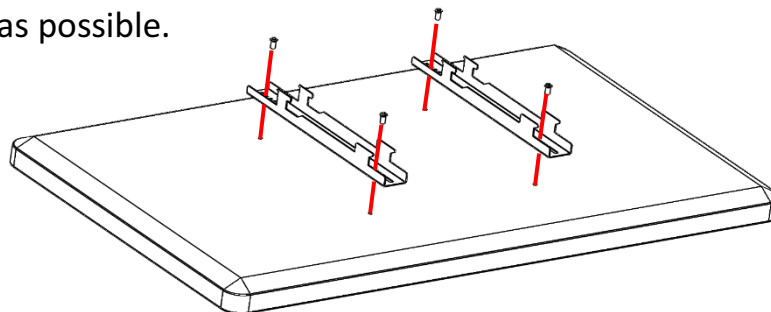

10. Make sure the casters on the base are locked, then hook the screen onto the mount plate.

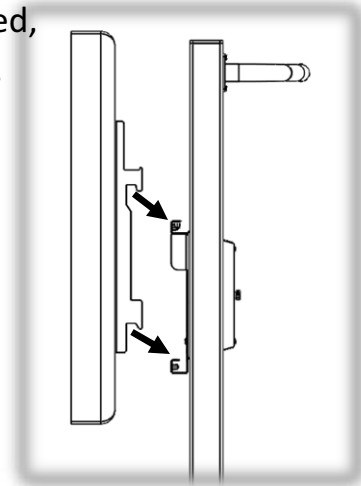

11. Secure the screen in place using the two clips and two M5*50mm bolts with washers.

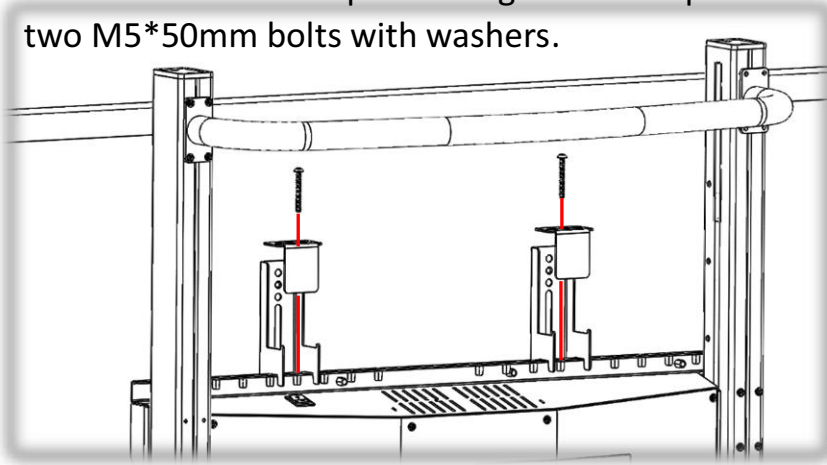

12. Use the switch indicated to raise and lower the screen when the power has been connected, please read all the safety information and warnings before operation. Check that there is sufficient clearance under the screen when in its fully lowered position that a trap is not formed.

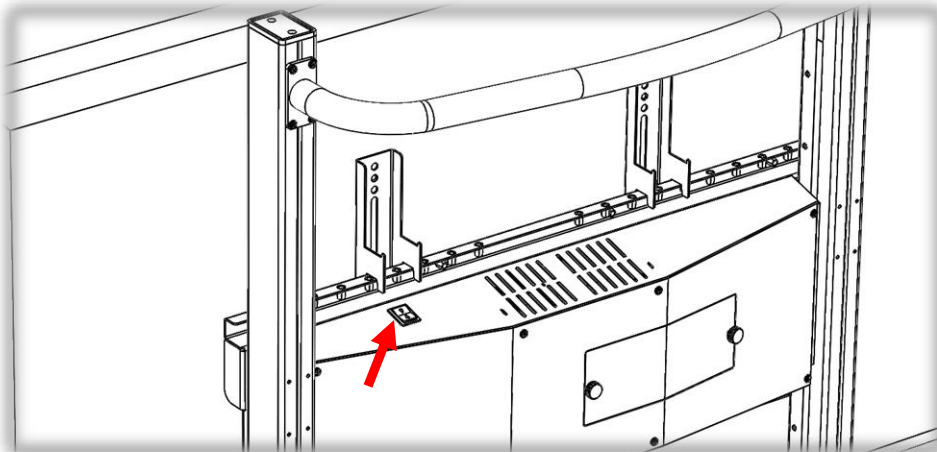

The Hi-Lo 750 trolley is an electrically powered height adjustable trolley for the mounting of large format and touchscreen displays.

WARNING

The product is shipped fully assembled on a custom pallet to prevent movement during transport. If the unit is being stored do not double stack. To unpack remove the banding and lift the outer carton off the unit.

Release the inner banding, release the castor brakes. The unit is stable. Carefully manoeuvre the unit off the pallet. This is a two person operation. Retain all packaging until the unit has been inspected for damage.

When moving the unit the screen must be lowered to its lowest position. Ensure that all castors are released from their brakes and are running freely. This unit is not designed for rough terrain. Please treat sympathetically avoiding kerbs or changes in level and being especially careful when changing floor surfaces or crossing sloping areas. Take your time. If in doubt ask a second person to assist you.

Maintenance Instructions

There are no user maintenance or adjustment points on this machine. Simply clean dust and dirt from the outside of the unit and inspect for damage or breaks. Cleaners and disinfectants must not be highly alkaline or acidic.

The user should visually check the equipment for signs of wear or misuse before each time of using and for the security of the screen or any accessories. The condition of electrical cables and plugs should be checked for wear or abrasion before use.

In addition, the equipment should be visually inspected in more detail every three months to ensure that the unit is functioning properly and if it is not the user should report this to the manufacturer for advice or for the return of the unit to base for repair.

Incidences of misuse must be reported immediately and the unit placed out of commission.

All repairs to the unit must only be carried out in Loxit's workshops as special tools must be used.

The warranty is only valid in so far as the equipment has been used and maintained correctly and has not been tampered with.

Violent treatment will invalidate the warranty.

During operation if the unit makes any unusual noises or smells turn off the power supply at the mains immediately.

Continuous use maximum period 2 minutes. Maximum use 10% (6 minutes in any hour).
Ambient temperature range +5deg C to +40 deg C.

The noise produced by the unit when static is silent which represents 99% of the time in use.

The noise produced by the unit when moving is consistent with other office equipment and would by comparison be rated as low.

Screen Lift Kit Contents

Kit	Quantity
Instructions	1
Cable tie	3
5mm Allen Key	1
4mm Allen key	1
3mm Allen key	1
Security Allen key	1
M8*20mm button head	4
M8*40mm button head	4
M6*16mm button head	4
M6*25mm button head	4
M6 Washer	4
M8 Washer	4
M6*12mm button head (may already be installed)	4
White caps/buttons	16

Bracket Pack Contents (may already be installed)

Kit	Quantity
Mount plate	1
Screen hangers	2
Security clips	2
M6*50 button head	2

Trouble shooting

If the electric lift will not operate up or down when pushing the manual rocker switch, please complete the following checks in order to evaluate or solve the problem.

Check the AC mains supply

If the mains plug is fused check the fuse is ok. Check the wall socket is working by connecting another appliance into the same socket to test that it works.

Check the AC mains transformer power supply

Disconnect from the AC mains socket and remove the back cover of the motor unit by removing the small screws. Reconnect the AC mains and carefully look inside to see whether the red light is showing on the power supply transformer.

If it is not then carefully unplug the connection between the transformer and AC mains cable. Wait at least 10 seconds and then carefully reconnect the AC mains cable to the power supply transformer, making sure you push the plug in firmly.

Check the remote receiver control box

With the back cover removed as above you will see that the manual rocker switch is connected to this box. Check if there is a blue light showing on the box. If there is not then carefully disconnect the manual rocker switch cable from the box and also disconnect the cable coming from the mains transformer power supply. Then carefully reconnect both of these.

If the unit is still not working please report this to your dealer for advice.

If the electric lift will not operate down or is stopping intermittently when pushing the manual rocker down switch, please complete the following checks in order to evaluate or solve the problem.

Check the weight loading

Be sure that the weight of the mounted monitor/board or equipment is more than the minimum 5 kilos but less than the maximum central loading of 100kg.

If it is more than 5kg but less than 25kg then add some pressure from your own body weight by centrally pushing down on the lift motor unit housing while the 'down' rocker switch is operated, if this works then run the lift up and down a few times with your hand pushing down in the same way to add some extra weight.

If the lift is working with this extra weight then providing your added equipment is less than 25kg, slightly loosen all screws fixing the handle to the columns, then carefully retighten the handle mounting screws as evenly as possible. Then repeat the first part again. The lift should now operate without the need for you to apply extra downward pressure.

If your equipment is more than 25kg already on the lift or if after completing the above the lift is still not operating correctly then contact your dealer for advice

Declaration of Conformity

The following product has been tested with the listed standards and found in compliance with the Council Directives detailed below.

Manufacturer:

Loxit Limited. First Avenue, Poynton Industrial Estate, Poynton, Cheshire, SK12 1YJ, England.

Type of Equipment:

Description: TV Wall Lift
Trademark: Loxit
Model Name: Screen Lift 750 Trolley Mount
Model Number: 8960

Technical Data: Input 230V, 50Hz, 80 watts

Test Standards: Complies with the following standards and other normative documents:

2006/42/EC

The Machinery Directive

2006/95/EC

Low Voltage Directive (LVD) relating to electrical equipment designed for use within certain voltage limits (codified version) according to the standard EN 60335-1:2006

2004/108/EC according to the standards EN 55014-1:2007, EN 55014-2:1997, EN 61000-3-2:2006, EN 61000-3-3:2008

EMC Directive

After preparation of the necessary technical documentation as well as the conformity declaration the CE marking as shown below can be affixed on the equipment and/or included in relevant documentation.



This declaration is issued under the sole responsibility of Loxit Ltd.

Signed *John Whittle*

Name..... *JOHN WHITTLE*

Effective Date: 09