

Hi Lo Mono 500/600 – Wall Mounted 8430 and 8431

-Max capacity 130kg -Screens upto 86"

1. If using adjustable feet thread the feet into the base of the column, then stand the column upright and use the feet to level it.

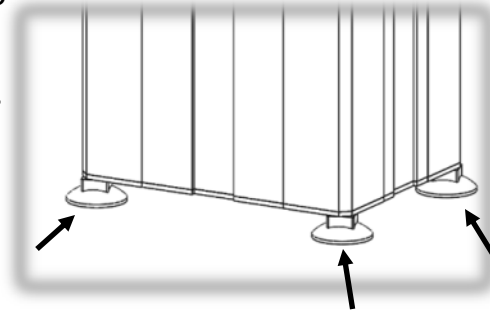

2. Bolt the brackets to the column as shown using four M8*16mm bolts for each bracket.

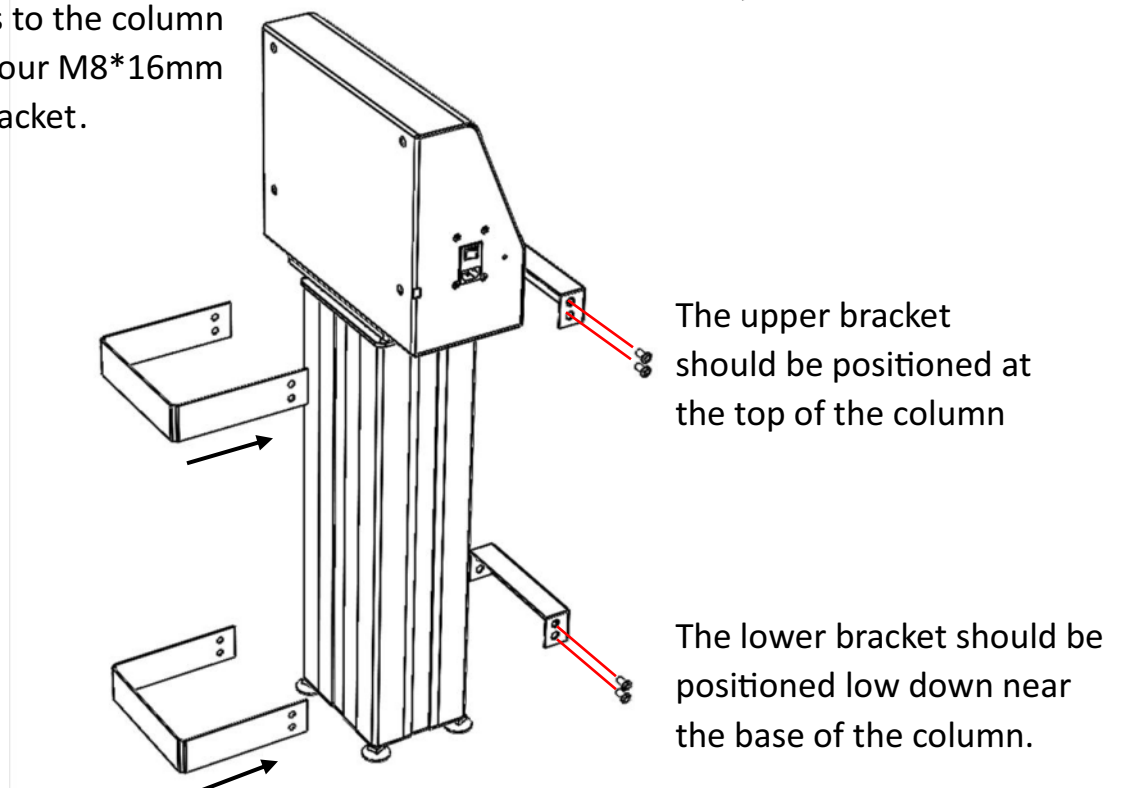

3. Move the column against the wall where it will be mounted and mark the positions of the brackets on the wall.
4. Move the column away from the wall and remove the brackets. Place the brackets against the marks made in the previous step and mark the positions of your fixings in the slots.

5. Drill the holes for the fixings and then attach the mounts to the wall using the appropriate fixings. Make sure that the brackets are vertically aligned.

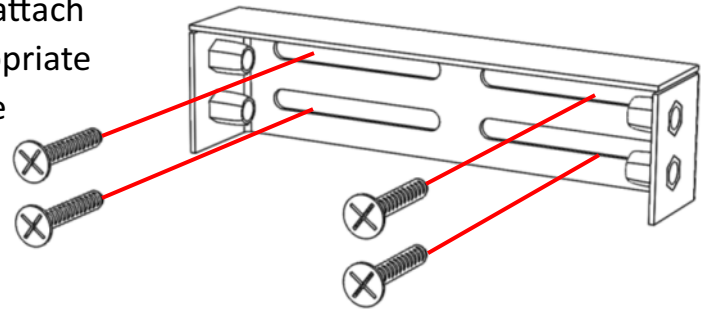

6. Move the column up against the two brackets on the wall, then slide the U-shaped part of bracket around the column and bolt it in place using four M8 bolts for each bracket.

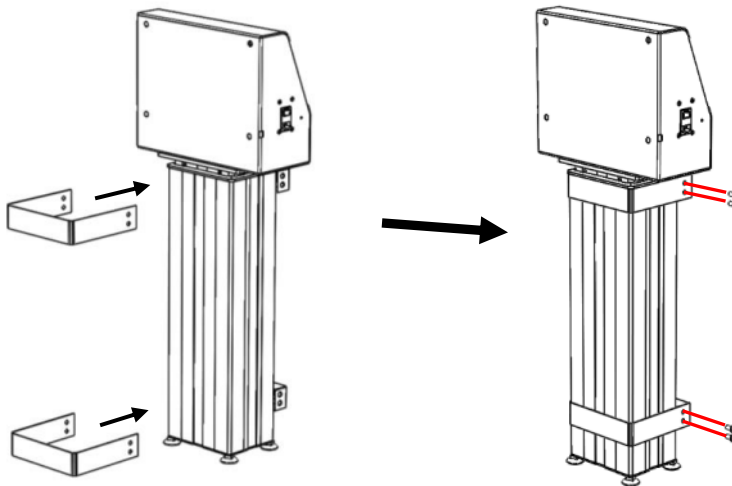

7. Bolt the mount plate in place using four M8 bolts.

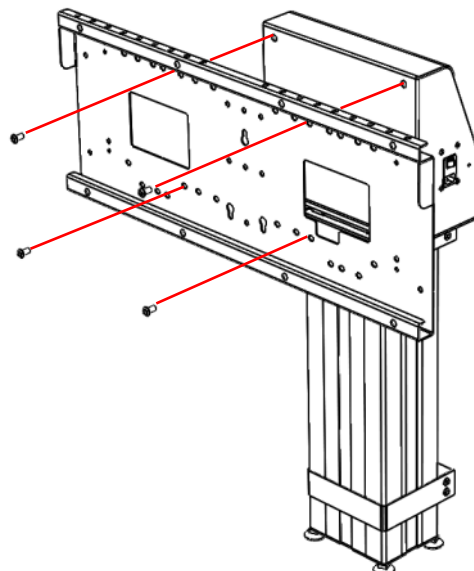

8. Attach the brackets to the back of the screen .

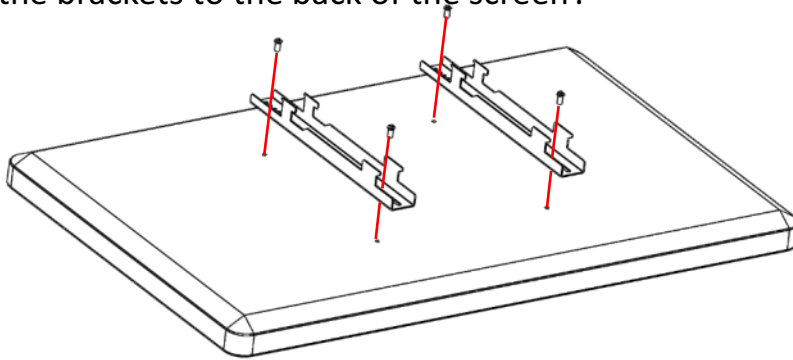

9. Hook the screen on to the mount rail.

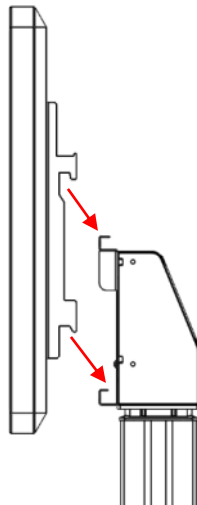

10. Secure the screen in place using the clips and two M6*50mm bolts.

