

Mono Fixed Height - Free Standing 8428

- Max load 130kg - Screens upto 86"

1. Use the four countersunk M10 bolts to secure the base to the column.

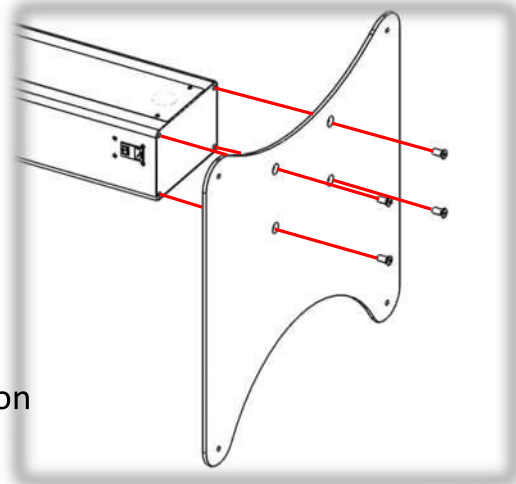

2. Move the free standing mount into position and bolt to the floor if necessary.

3. Remove the grommets from the front of the column. Then secure the mount in place using four M8*20mm bolts, the mount can be bolted in 5 different positions and offers 400mm of height adjustment in 100mm increments.

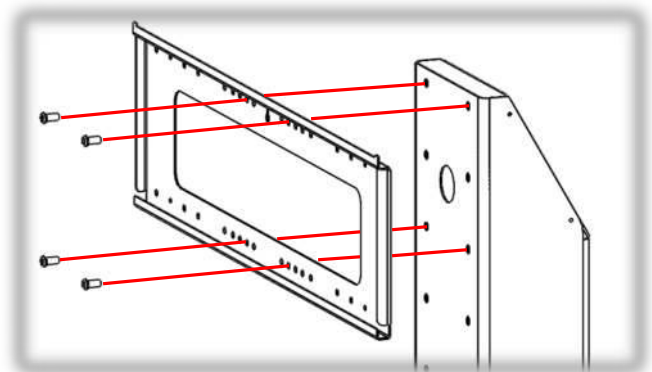

4. Fix the brackets to the back of the screen using fixings of an appropriate size and length for your screen. Ensure the brackets are as central as possible.

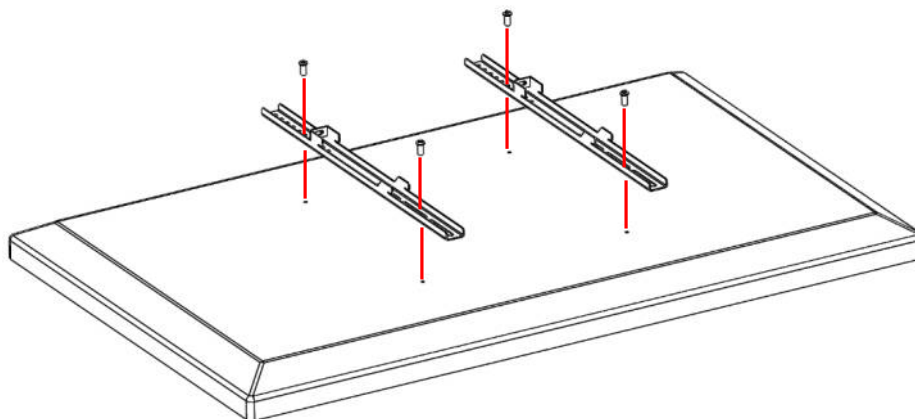

5. Hook the screen onto the mount rail.

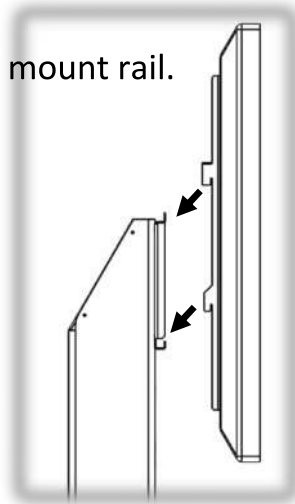

6. Secure the screen in place by fixing through the brackets into the mount plate, use the M6x50mm Bolts and large stainless washers provided. Do not overtighten the bolts.

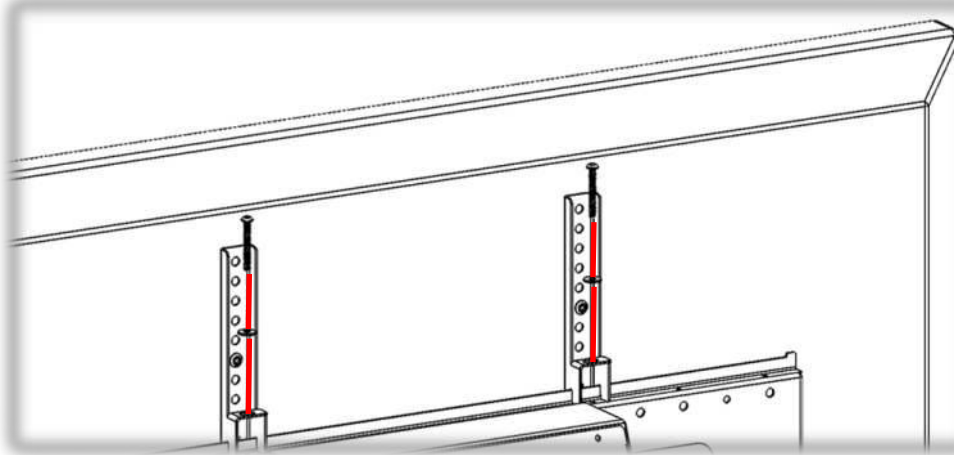

7. Unscrew the four M4 bolts and remove the rear cover. Pass power cables for the screen through the grommet on the front of the column and plug into the 4 way power strip. Once cabling is complete bolt the cover back in place.

