

Hi-Lo Mono 500 LED/LCD Free Standing - 8425

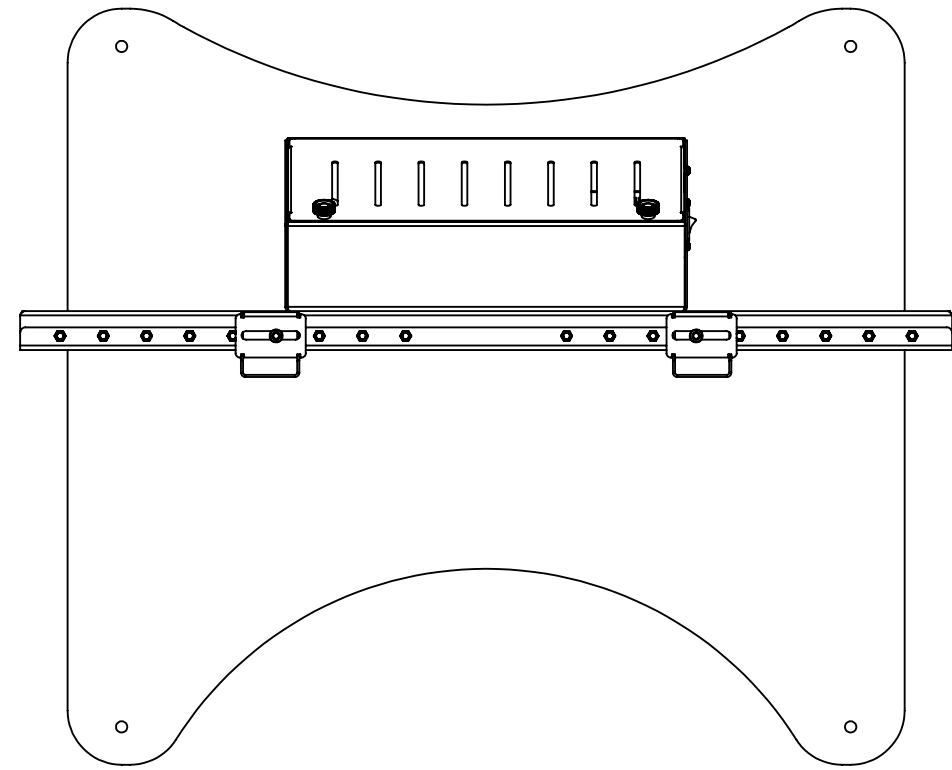

42 - 86" Screens

Max capacity 130kg

500mm Electric height adjustment
(880 - 1380mm)

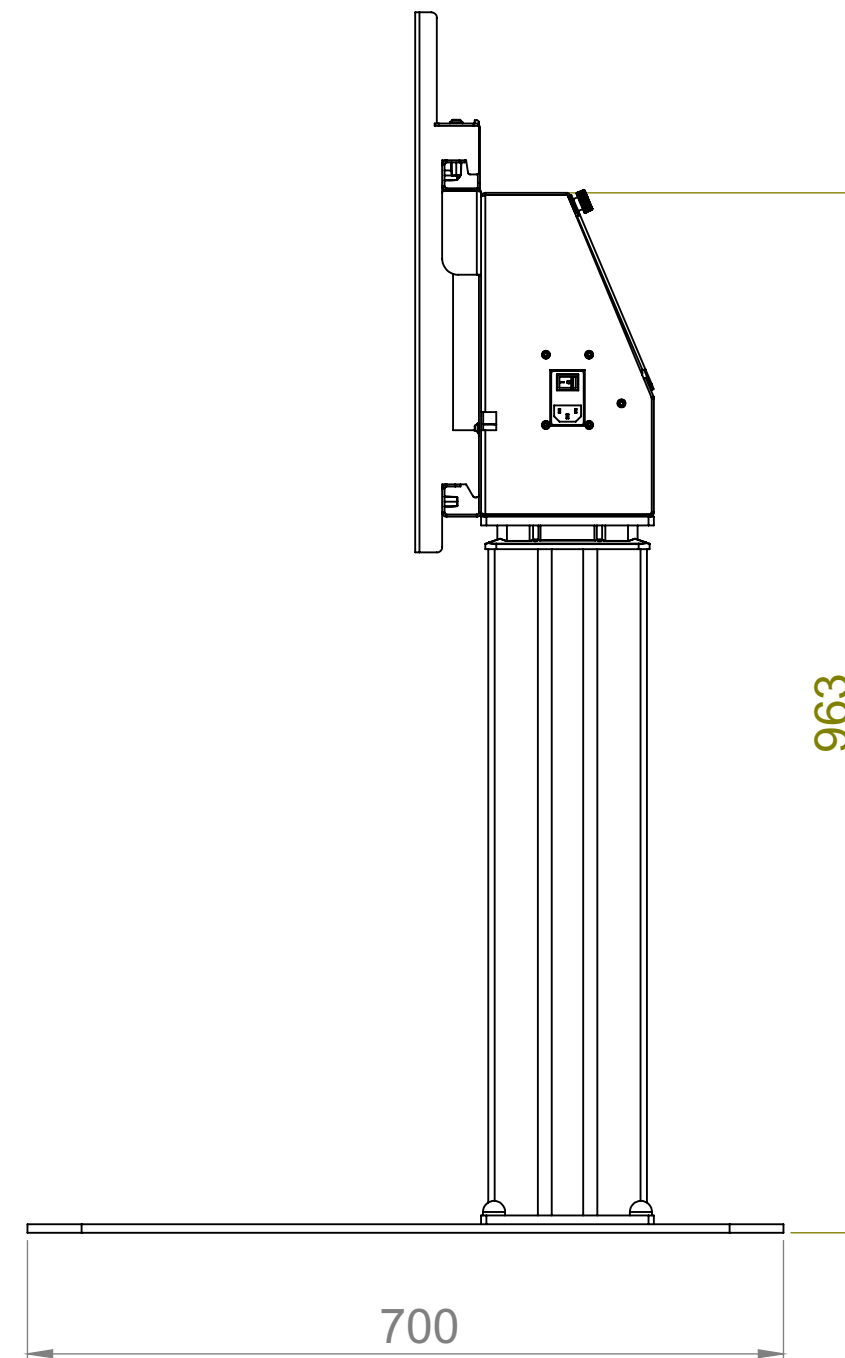
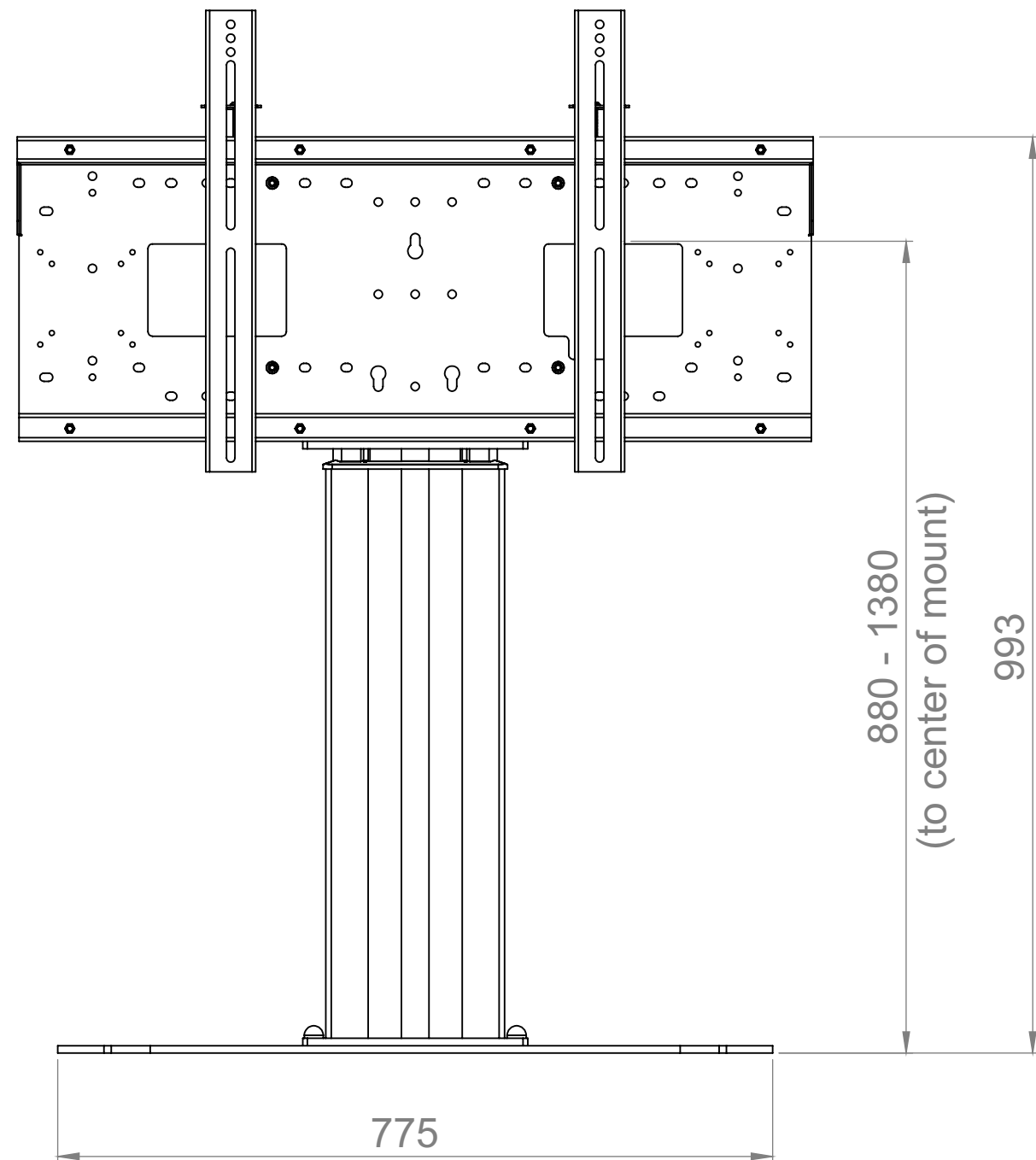
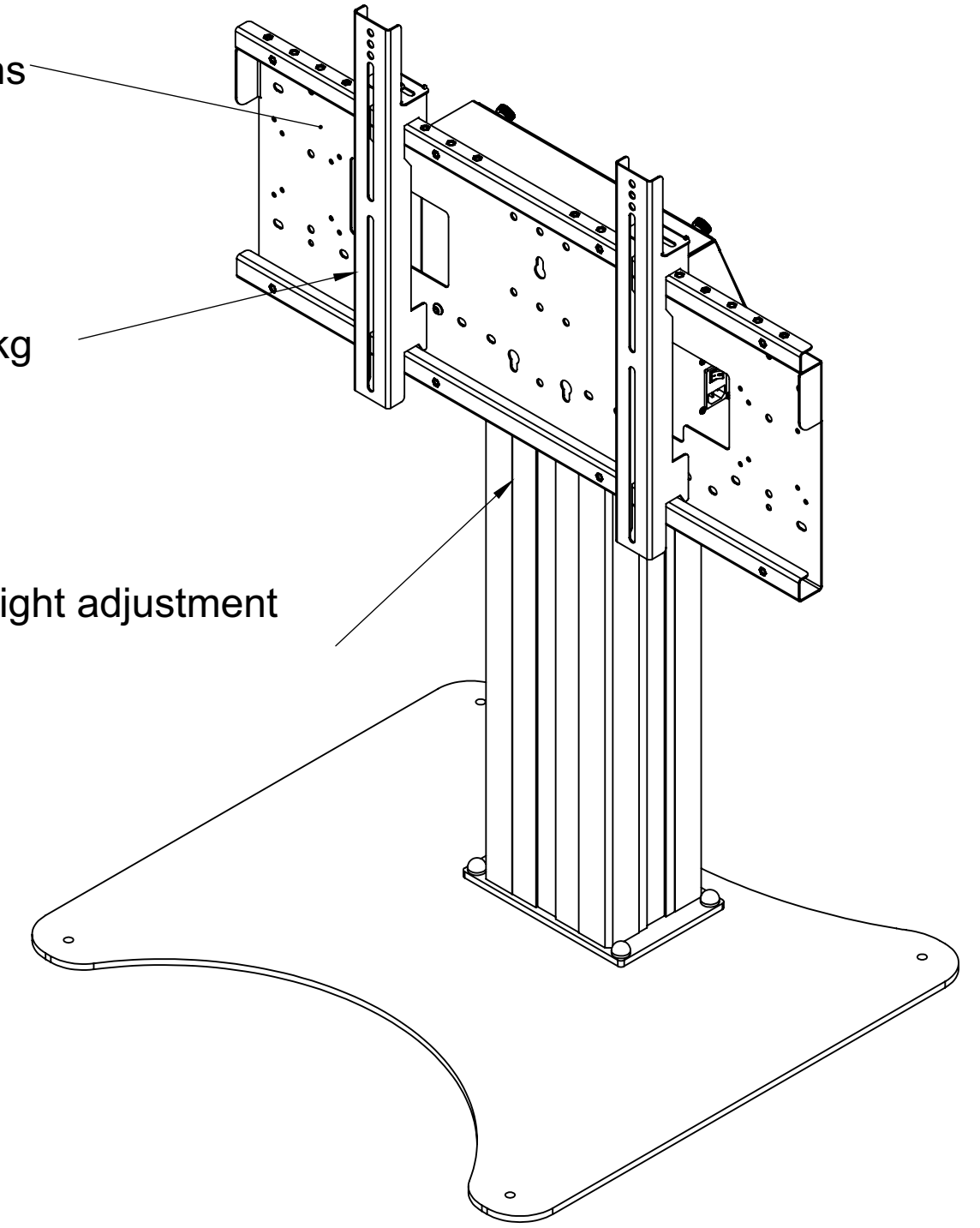

LOXKIT
PRODUCTS

Go Education Limited
Education House
1 Liberty Centre
Mount Pleasant
Wembley
Middlesex
Ha0 1TX
t: +44 (0) 20 8795 3882
w: www.goeducation.co.uk

The copyright of this drawing is retained by Loxit limited
This drawing may not be reproduced without prior written permission of Loxit limited

*Dimensions given to a tolerance of +/-5mm